

## Model: HA55

Closed loop,PCB welding type;  
Detect DC,AC and pulse current.

### Technical index:

Flame resistance: UL94-V0  
Operating temperature: -10~+70°C  
Storage temperature: -40~+85°C  
Bandwidth: DC~150kHz  
Dielectric strength: 2.5KV 50Hz 1min



### Electric parameters:

$I_p$	Rated input	$\pm 100$	A
$I_{PM}$	Input measured range	$\pm 150$	A
$I_{OUT}$	Rated output	$\pm 50$	mA
X	Accuracy	0.5	%
$\epsilon_L$	Linearity	$< 0.1$	%
$V_C$	Supply voltage( $\pm 5\%$ )	$\pm 15$	V
$I_C$	Current consumption	$\pm 10$	mA+Im
$R_L$	Load impedance	110	$\Omega$
$I_{OE}$	Zero offsetTA=25°C	$\leq \pm 0.15$	mA
$T_R$	Response time	$< 1$	$\mu s$
N.W	Weight	17	g

### Schematic diagram:

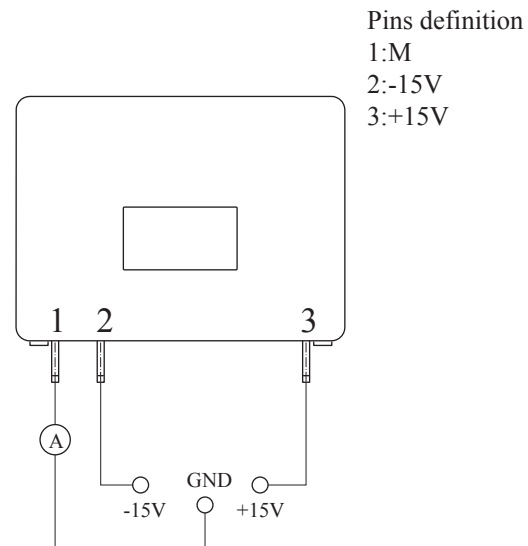

### Dimensions ( in mm ) :

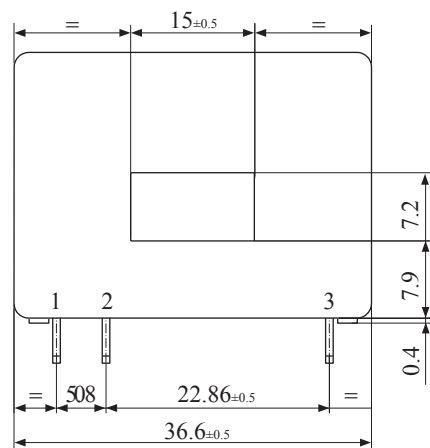

Front view

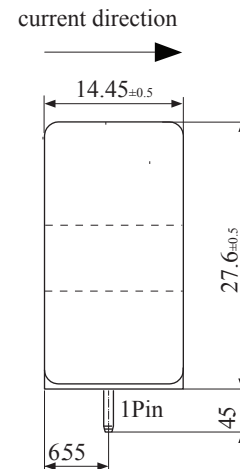

Side view