

Model: HA2020

Epoxy potting plug terminal, leading wire or PCB welding output.AC/DC motor, current and voltage detection, battery powered, charging current detection, welding machine, inverter, automatic elevator, crane, papermaking,printing presses, injection molding machine, elevator Mechanical and electrical equipment such as AC/DC current/voltage detection



Technical index:

- Flame resistance: UL94-V0
- Operating temperature: -25~+70°C
- Storage temperature: -40~+85°C
- Bandwidth: DC~150kHz
- Dielectric strength: 6KV 50Hz 1min

Electric parameters:

I_p	Rated input	± 300	A
I_{PM}	Input measured range	± 450	A
I_{OUT}	Rated output	± 150	mA
X	Accuracy	0.5	%
ϵ_L	Linearity	< 0.1	%
V_C	Supply voltage($\pm 5\%$)	± 15	V
I_C	Current consumption	± 17	mA+Im
R_L	Load impedance	40	Ω
I_{OE}	Zero offsetTA=25°C	$\leq \pm 0.15$	mA
T_R	Response time	< 1	μs
N.W	Weight	88	g

Schematic diagram:

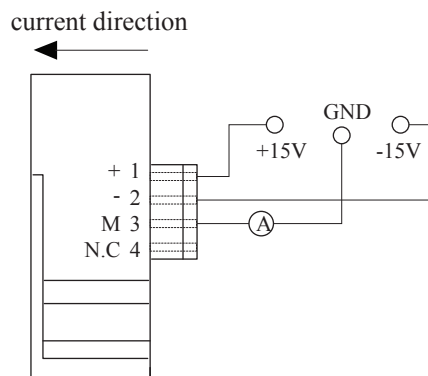

connector schematic diagram:

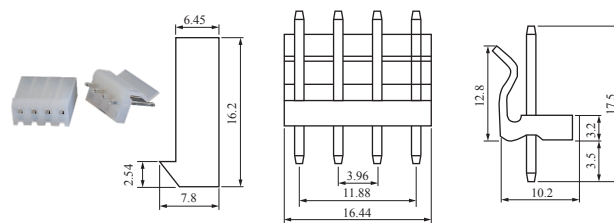

Cold-press terminal plug /socket,Distance 3.96, Stitch size 1×1

Dimensions (in mm) :

