

Model • HAB55

Closed loop hall current sensor, hall magnetic compensation principle, can isolated measure AC, DC, pulse current.

Technical index:

Flame resistance: UL94-V0

Operating temperature: -25~+70°C

Storage temperature: -25~+100°C

Bandwidth: DC~150kHz

Dielectric strength: 2.5KV 50Hz 1min



Electric parameters:

I_P	Rated input	± 50	A
I_{PM}	Input measured range	± 80	A
I_{OUT}	Rated output	± 50	mA
X	Accuracy	0.5	%
ϵ_L	Linearity	< 0.15	%
V_C	Supply voltage($\pm 5\%$)	± 15	V
I_C	Current consumption	± 10	mA+Im
R_L	Load impedance	10-100	Ω
I_{OE}	Zero offset TA=25°C	$\leq \pm 0.3$	mA
T_R	Response time	< 1	μs
N.W	Weight	16	g

Schematic diagram:

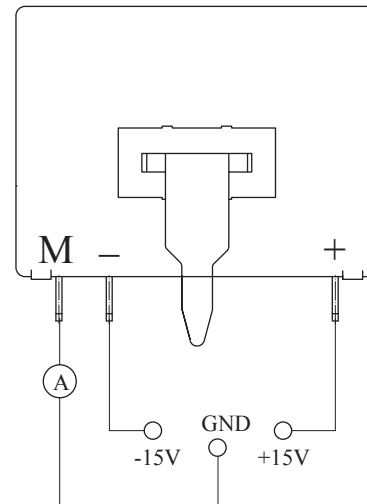

Dimensions (in mm) :

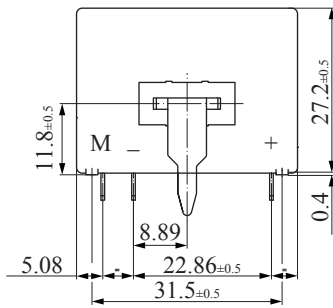

Front view

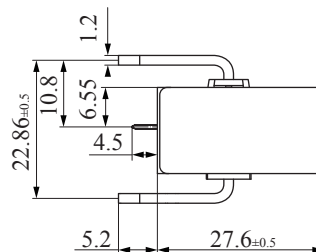

Side view

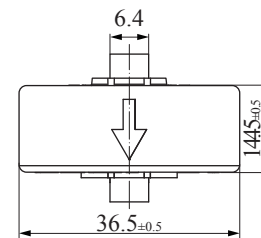

Top view